

Coverage chart

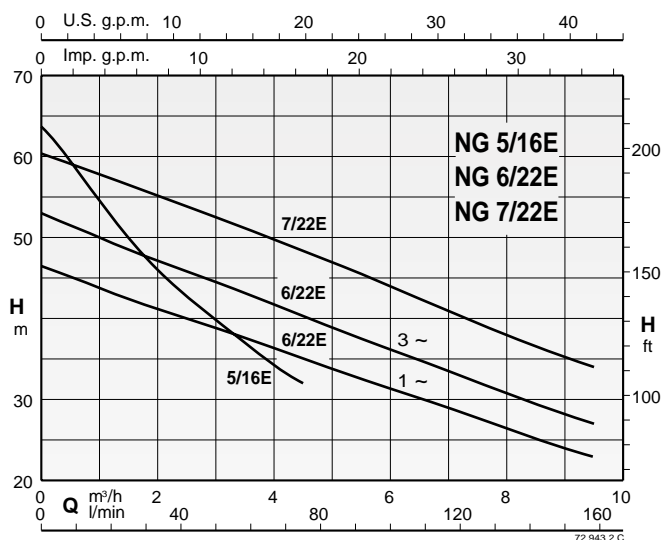

Characteristic, dimensions and weights

GETTOMAT

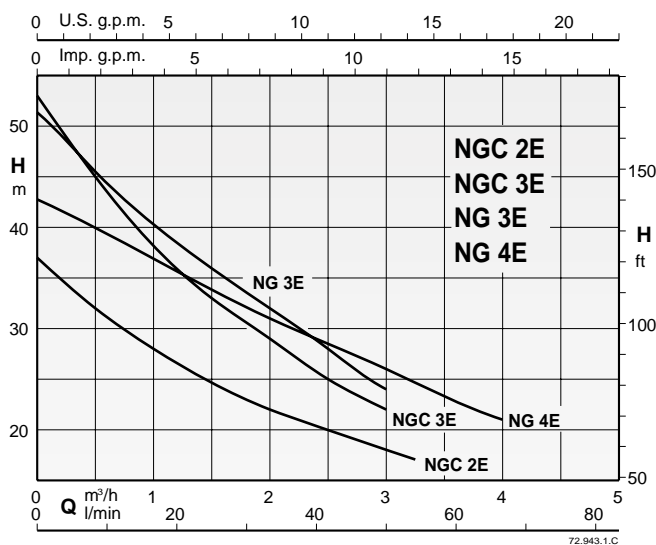
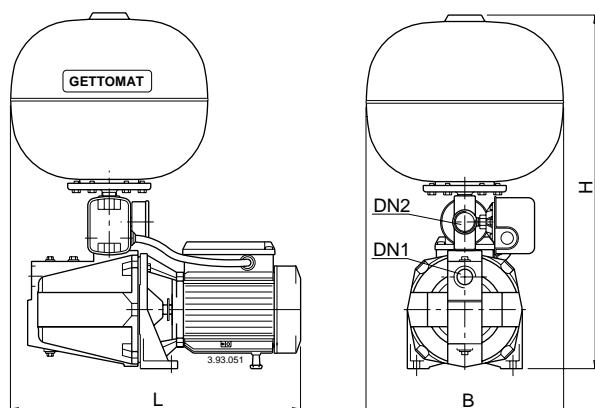

GETTOMAT 1/1

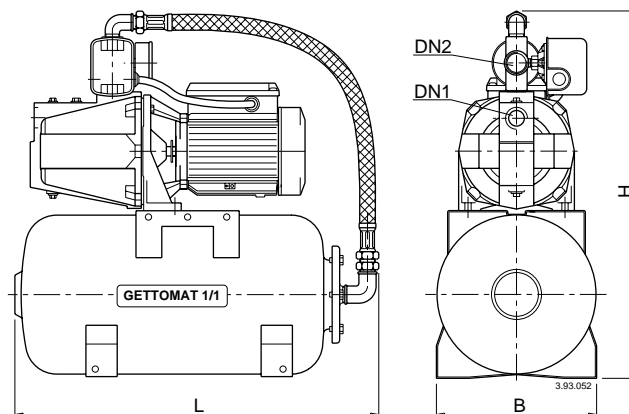

GETTOMAT

3~	1~	kW	HP	Q max * l/min	Pressostato Pres. switch bar	DN1	DN2	mm			kg
								B	L	H	
NGC 2E/24	NGCM 2E/24	0,45	0,6	50	1,8÷3,0	G1	G1	360	460	525	18,5
NGC 3E/24	NGCM 3E/24	0,55	0,75	45	2,5÷4,0	G1	G1		525	19,5	
NG 3E/24	NGM 3E/24	0,55	0,75	50	2,5÷4,0	G1	G1		610	25,1	
NG 4E/24	NGM 4E/24	0,75	1	65	2,0÷3,5	G1	G1		610	28,9	
NG 5/16E/24	NGM 5/16E/24	1,1	1,5	65	3,5÷5,0	G 1 1/2	G1	570	650	35,5	
NG 6/22E/24	NGM 6/22E/24	1,5	2	140	2,5÷4,0	G 1 1/2	G1		650	37,5	
NG 7/22E/24	-	2,2	3	150	3,5÷5,0	G 1 1/2	G1		650	39,5	

GETTOMAT 1/1

3~	1~	kW	HP	Q max * l/min	Pressostato Pres. switch bar	DN1	DN2	mm			kg
								B	L	H	
NGC 2E/20	NGCM 2E/20	0,45	0,6	50	1,8÷3,0	G1	G1	255	540	525	19
NGC 3E/20	NGCM 3E/20	0,55	0,75	45	2,5÷4,0	G1	G1		525	20	
NG 3E/20	NGM 3E/20	0,55	0,75	50	2,5÷4,0	G1	G1		610	26	
NG 4E/20	NGM 4E/20	0,75	1	65	2,0÷3,5	G1	G1		610	29,7	
NG 5/16E/20	NGM 5/16E/20	1,1	1,5	65	3,5÷5,0	G 1 1/2	G1	580	640	36,2	
NG 6/22E/20	NGM 6/22E/20	1,5	2	140	2,5÷4,0	G 1 1/2	G1		640	38,5	
NG 7/22E/20	-	2,2	3	150	3,5÷5,0	G 1 1/2	G1		640	40	

* Maximum pump flow at minimum set pressure of pressure switch.