

Coverage chart

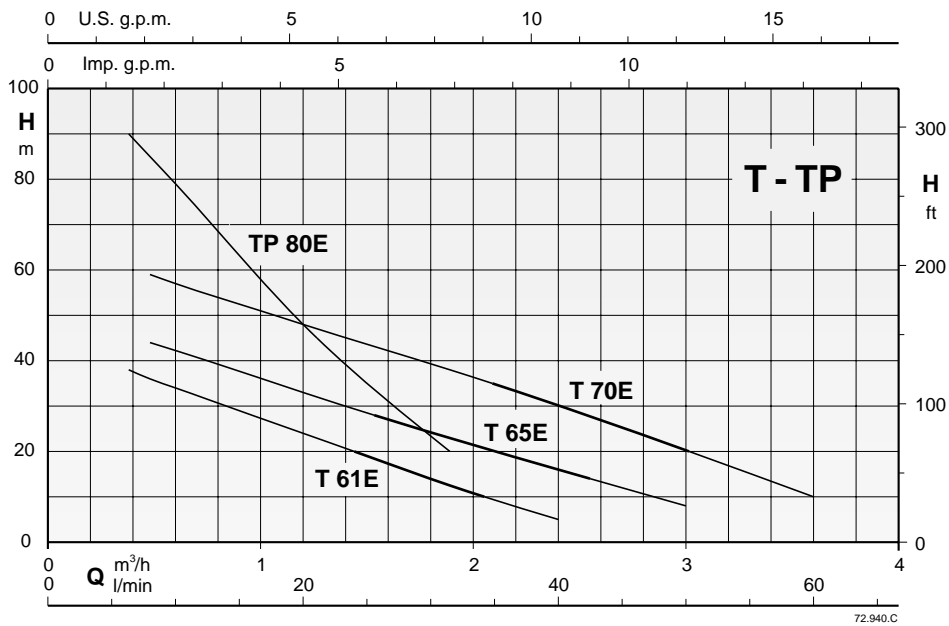

Characteristic, dimensions and weights

TURBOMAT

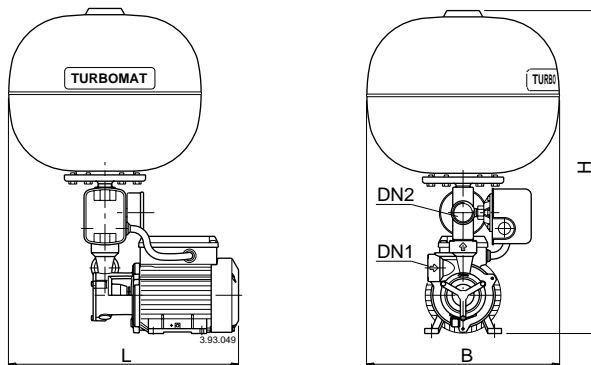

TURBOMAT 1/1

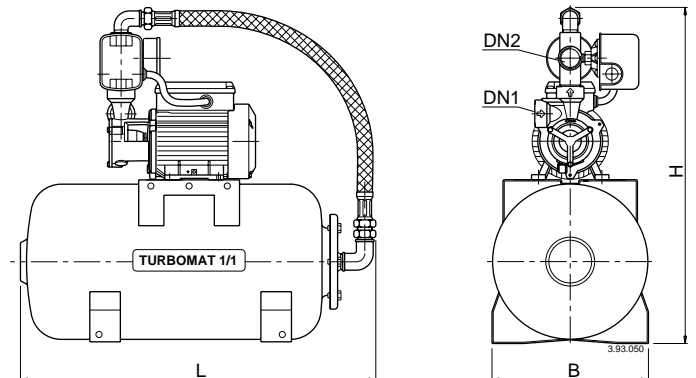

TURBOMAT

3~ 230/400V	1~ 230V	kW	HP	Q max* l/min	Pressostato Pres. switch bar	DN1	DN2	mm			kg
								B	L	H	
T 61E/24	TM 61E/24	0,33	0,45	32	1,4÷2,8	G1	G1	360	400	560	13,3
T 65E/24	TM 65E/24	0,45	0,6	43	1,4÷2,8	G1	G1		400	560	13,3
T 70E/24	TM 70E/24	0,75	1	50	2,0÷3,5	G1	G1		430	575	17,7
TP 80E/24	TPM 80E/24	0,75	1	22	4,5÷6,0	G 3/4	G1	485	575	22	

TURBOMAT 1/1

3~ 230/400V	1~ 230 V	kW	HP	Q max* l/min	Pressostato Pres. switch bar	DN1	DN2	mm			kg
								B	L	H	
T 61E/20	TM 61E/20	0,33	0,45	32	1,4÷2,8	G1	G1	255	540	565	25
T 65E/20	TM 65E/20	0,45	0,6	43	1,4÷2,8	G1	G1			565	25
T 70E/20	TM 70E/20	0,75	1	50	2,0÷3,5	G1	G1			585	29
TP 80E/20	TPM 80E/20	0,75	1	22	4,5÷6,0	G 3/4	G1			585	32,2

* Maximum pump flow at minimum set pressure of pressure switch.